





D.Ye. Yelubayev<sup>1,2</sup> , Z.E. Ongaibergenov<sup>1,2</sup> , A.U. Utegenov<sup>1,2</sup> ,  
R.Ye. Zhumadilov<sup>1,2,\*</sup> 

<sup>1</sup>Institute of Applied Sciences and Information Technologies, Almaty, Kazakhstan

<sup>2</sup>Al-Farabi Kazakh National University, Almaty, Kazakhstan

\*e-mail: [rakimzhan@gmail.com](mailto:rakimzhan@gmail.com)

## SPECTRAL CHARACTERISTICS OF ARGON AND ARGON-METHANE PLASMA OBTAINED IN AN RF-DBD REACTOR AT LOW PRESSURE

This paper investigates the properties and spectral characteristics of low-temperature argon plasma and argon-methane mixture plasma formed in a high-frequency dielectric barrier discharge (RF-DBD) at various powers and pressures. The experiments were conducted at an argon flow rate of 100 sccm for argon plasma and at a ratio of Ar:CH<sub>4</sub> = 95:5 for argon-methane plasma in the power range from 2 to 12 W and pressures of 0.5 and 1.0 Torr. It is shown that with an increase in the supplied power, the discharge area expands and the intensity of spectral lines increases, which is due to an increase in plasma density and the degree of ionisation. When the pressure increases, there is a decrease in the overall intensity of radiation due to a reduction in the free path length of electrons and an increase in collision losses. The introduction of methane leads to a decrease in the intensity of the spectral lines of molecular nitrogen and hydroxyl radicals (OH) compared to argon plasma, which indicates a redistribution of electron energy in favour of the excitation of argon atoms and active methane particles. The results obtained contribute to a deeper understanding of the physicochemical processes in Ar-CH<sub>4</sub> plasma and open up prospects for the application of RF-DBD discharges in plasma chemistry and materials science.

**Key words:** dielectric barrier discharge, RF-DBD reactor, optical spectroscopy, argon plasma, argon-methane plasma, plasma chemistry.

Д.Е. Елубаев<sup>1,2</sup>, Ж.Е. Оңайбергенов<sup>1,2</sup>, А.У. Утегенов<sup>1,2</sup>, Р.Е. Жумадилов<sup>1,2\*</sup>

<sup>1</sup>Қолданбалы ғылымдар және ақпараттық технологиялар институты, Алматы, Қазақстан

<sup>2</sup>Әл-Фараби атындағы Қазақ ұлттық университеті, Алматы, Қазақстан

\*e-mail: [rakimzhan@gmail.com](mailto:rakimzhan@gmail.com)

## Төмен қысымды RF-DBD реакторында алынған аргон және аргон-метан плазмасының спектрлік сипаттамалары

Бұл жұмыс әртүрлі қуаттар мен қысымдарда жоғары жиілікті диэлектрлік барьерлік разрядында (RF-DBD) түзілген төмен температуралы аргон плазмасының және аргон-метан қоспасының ерекшеліктері мен спектрлік сипаттамаларын зерттеді. Эксперименттер аргон плазмасы үшін 100 ссст аргон ағынында және 2-ден 12 Вт-қа дейінгі қуат диапазонында және 0,5 және 1,0 Торр қысымында аргон-метан плазмасы үшін Ar:CH<sub>4</sub> = 95:5 қатынасында жүргізілді. Берілген қуаттың жоғарылауымен разряд аймағының кеңеюі және спектрлік сызықтардың интенсивтілігінің жоғарылауы байқалады, бұл плазма тығыздығы мен иондану дәрежесінің жоғарылауына байланысты. Қысымның жоғарылауымен электрондардың еркін жүру ұзындығының қысқаруы және соқтығысу шығындарының жоғарылауы салдарынан сәулеленудің жалпы қарқындылығының төмендеуі байқалады. Метанды енгізу аргон плазмасымен салыстырғанда молекулалық азот пен гидроксил радикалдарының (OH) спектрлік сызықтарының интенсивтілігінің төмендеуіне әкеледі, бұл аргон атомдары мен метанның белсенді бөлшектерін қоздыру пайдасына электрондардың энергиясының қайта бөлінуін көрсетеді. Нәтижелер Ar-CH<sub>4</sub> плазмасындағы физика-

химиялық процестерді тереңірек түсінуге ықпал етеді және плазмалық химия және материалтану мәселелерінде RF-DBD разрядтарын қолдану перспективаларын ашады.

**Түйін сөздер:** диэлектрлік барьерлік разряд, RF-DBD реакторы, оптикалық спектроскопия, аргон плазмасы, аргон-метан плазмасы, плазмалық химия.

Д.Е. Елубаев<sup>1,2</sup>, Ж.Е. Оңайбергенов<sup>1,2</sup>, А.У. Утегенов<sup>1,2</sup>, Р.Е. Жумадилов<sup>1,2\*</sup>

<sup>1</sup>Институт прикладных наук и информационных технологий, Алматы, Казахстан

<sup>2</sup>Казахский национальный университет им. аль-Фараби, Алматы, Казахстан

\*e-mail: [rakimzhan@gmail.com](mailto:rakimzhan@gmail.com)

### Спектральные характеристики аргонной и аргон-метановой плазмы, полученной в RF-DBD реакторе при низком давлении

В данной работе исследованы особенности и спектральные характеристики низкотемпературной плазмы аргона и аргон-метановой смеси, сформированной в высокочастотном диэлектрическом барьерном разряде (RF-DBD) при различных мощностях и давлениях. Эксперименты проводились при расходе аргона 100 ссст для аргонной плазмы и при соотношении  $\text{Ar}:\text{CH}_4 = 95:5$  для аргон-метановой плазмы в диапазоне мощностей от 2 до 12 Вт и давлениях 0,5 и 1,0 Торр. Показано, что с увеличением подводимой мощности происходит расширение области разряда и рост интенсивности спектральных линий, что обусловлено увеличением плотности плазмы и степени ионизации. При повышении давления наблюдается снижение общей интенсивности излучения вследствие сокращения длины свободного пробега электронов и возрастания столкновительных потерь. Введение метана приводит к уменьшению интенсивности спектральных линий молекулярного азота и гидроксильных радикалов (OH) по сравнению с аргонной плазмой, что свидетельствует о перераспределении энергии электронов в пользу возбуждения атомов аргона и активных частиц метана. Полученные результаты способствуют более глубокому пониманию физико-химических процессов в плазме  $\text{Ar}-\text{CH}_4$  и открывают перспективы для применения RF-DBD разрядов в задачах плазменной химии и материаловедения.

**Ключевые слова:** диэлектрический барьерный разряд, RF-DBD реактор, оптическая спектроскопия, аргонная плазма, аргон-метановая плазма, плазменная химия.

### Introduction

The global transition to alternative energy sources is driven by the negative impact of fossil fuels, which result in greenhouse gas emissions. Traditional energy sources are limited and significantly contribute to  $\text{CO}_2$  release and global warming. In recent years, various decarbonisation technologies have been investigated, aiming at zero or low carbon emissions. There are many potential solutions to the decarbonisation challenge, among which hydrogen stands out as a carbon-free fuel for fuel cells and internal combustion engines. Hydrogen is recognised as a promising substitute for conventional energy sources due to its unique properties. It is also an excellent energy carrier with negligible emissions and can be obtained from a variety of resources. As the most abundant and lightest element on Earth, hydrogen can be produced and utilized without harming the environment, producing only water as a by-product [1-4]. One of

the rapidly developing methods for minimising carbon emissions is non-thermal plasma catalysis. Plasma catalysis involves integrating a catalyst with plasma to achieve specific products at the required rate and efficiency. Plasma is a partially ionised gas consisting of neutral species (molecules, radicals, excited species), ions, photons, and electrons. [5,9]. Compared to thermal methods, non-thermal plasma (NTP) can be generated by exposing a neutral gas (e.g., argon) to an external electric field. Its non-equilibrium nature ensures that the bulk gas remains at room or low temperatures, while the temperature of high-energy electrons inside the plasma is an order of magnitude higher. Reactive plasma particles such as electrons, ions, excited molecular states, radicals and photons initiate processes that are thermodynamically impossible at low temperatures and atmospheric pressure but occur on the nanosecond timescale in plasma. Thus, plasma technologies represent a

promising solution to the problems associated with variability and unpredictability in the production and distribution of electricity. In addition, the use of catalysts enables precise control over process selectivity, allowing reactions to be directed along the desired paths and hydrogen to be efficiently obtained under plasma conditions. [5-10].

As previously mentioned, the interest in applying plasma technologies for hydrogen production has increased significantly in recent years. Various types of plasma have been employed in experimental studies. The most commonly used types include dielectric barrier discharges (DBD), microwave (MW), and gliding arc (GA) discharges, although other types have also been used, such as

## Experimental setup

A schematic diagram of the experimental setup for studying the spectral characteristics of low-temperature argon plasma and argon-methane mixture is shown in Fig. 1. The setup consists of a horizontally positioned quartz tube, 300 mm in length with an inner diameter of 16 mm. The discharge was generated between a 250 mm long stainless-steel rod (4 mm in outer diameter) and a grounded copper-tape electrode wrapped around the centre of the quartz tube, as shown in Fig. 1. The working chamber was evacuated using a fore-vacuum pump to a pressure of  $0,5 \cdot 10^{-2}$  Torr. The working gases (argon and methane) were fed into the system using mass flow controllers at a rate of 95 sccm for argon (or 100 sccm for pure argon) and 5 sccm for methane. The pressure in the system was monitored using an Edwards ADC Enhanced MKII pressure controller. Optical emission from the positive column region of the plasma was measured using an Optosky ATP 2000 spectrometer in the wavelength range of 200–1100 nm [13,14].

The experiments were conducted at various pressures (0.5 and 1.0 Torr) and discharge powers ranging from 2 to 12 W. During the measurements, the setup operated in continuous flow mode. The

## Results and discussion

### Argon plasma

The spectral characteristics of argon plasma at a flow rate of 100 sccm and a pressure of 0,5 Torr were recorded in the power range from 2 to 12 W (Fig. 2). As can be seen in Figure 2, with an increase in discharge power, a gradual expansion of the plasma glow area and an increase in optical emission intensity are observed. At a minimum power of 2 W, a weak, localized plasma glow is observed, which corresponds to the plasma ignition threshold power. With a further increase in power from 2 to 10 W, the

radio frequency, corona, glow, spark, and nanosecond pulse discharges [8]. DBD is a typical example of «non-thermal plasma», in which the gas remains at a temperature close to ambient conditions, while electrons are heated to 2–3 eV ( $\approx 20,000$ – $30,000$  K) under the action of a strong electric field. In contrast, MW and GA discharges fall into the category of warm plasmas, where the gas temperature can exceed 1000 K, and the electron energy usually reaches several eV [8,11].

This paper presents an experimental study on the spectral characteristics of argon and argon–methane plasmas generated in a vacuum reactor employing a high-frequency dielectric barrier discharge (RF-DBD).

volume fraction of methane ( $\text{CH}_4$ ) in the gas mixture was approximately 5%.

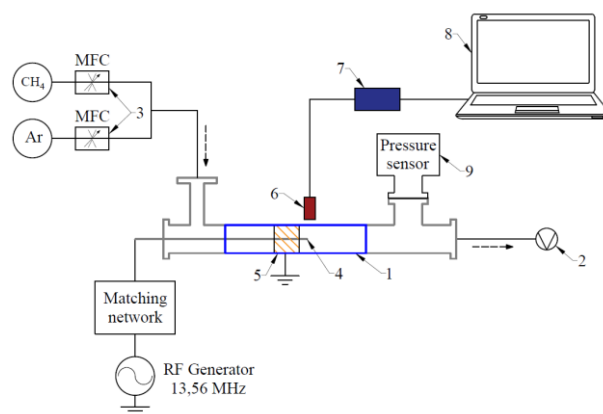

**Figure 1** – Schematic diagram of the experimental gas conversion setup: 1 – gas discharge quartz tube, 2 – fore-vacuum pump, 3 – gas mass flow controllers, 4 – high-frequency electrode, 5 – grounding electrode, 6 – detector, 7 – optical emission spectrometer, 8 – laptop, 9 – pressure sensor

plasma becomes brighter and evenly distributed along the quartz tube. This is due to an increase in electron density and collision frequency, which leads to more efficient excitation of argon atoms and, accordingly, to an increase in radiation intensity. At a power of 12 W, the quartz tube is almost completely filled with plasma. No further increase in power above 12 W was carried out, since under such conditions, parasitic (static) current may appear, which can negatively affect the correct operation of the pressure sensor installed near the discharge zone.

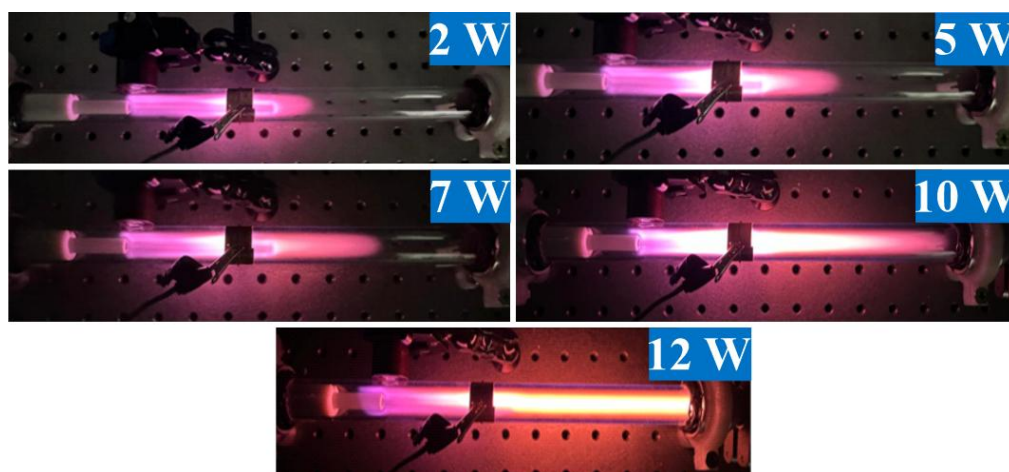

**Figure 2** – Photo of RF-DBD argon plasma discharge at various powers (2–12 W) with an argon flow rate of 100 sccm and a pressure of 0,5 Torr.

Figures 3 (a) and (b) show the emission spectra of argon plasma at a pressure of 0,5 Torr and powers of 5 W and 10 W, respectively. At a constant argon flow rate of 100 sccm and a pressure of 0,5 Torr, it can be seen that the intensity of the Ar I lines increases with an increase in power from 5 to 10 W. This is due to an increase in the ionization level and electron energy, which leads to an increase in the rate of electron-neutral impact excitation. As a result of collisions, electrons transfer part of their energy to argon atoms, causing their excitation and subsequent radiation when they transition to the ground state [15].

Photo of the RF-DBD argon plasma discharge obtained at different powers from 2 W to 12 W with an argon flow rate of 100 sccm at a pressure of 1,0 Torr are shown in Figure 4. As the power increases, the luminescence area expands, and the discharge gradually covers most of the quartz tube. In the 10–12 W power range, the plasma occupies almost the entire length of the tube, however, in contrast to the previous experiment conducted at a pressure of 0,5 Torr, here at 12 W the discharge does not spread to the other end of the quartz tube. This difference is due to the influence of pressure. An increase in pressure leads to a decrease in the free path length of electrons, and as a result, ionisation becomes more localised. Electrons lose energy due to frequent inelastic collisions with argon atoms, and part of the supplied energy is dissipated without effectively increasing the plasma density. As a result, at a pressure of 1,0 Torr, compression (shortening) of the plasma zone is observed.

Figures 5 (a) and (b) present the emission spectra of argon plasma recorded at a pressure of 1,0 Torr and powers of 5 W and 10 W, respectively.

At a pressure of 1,0 Torr, a similar trend is observed: with an increase in discharge power from 5 to 10 W, the intensity of the Ar I spectral lines increases, which is associated with an increase in electron energy and the intensification of electron-impact excitation and ionisation processes.

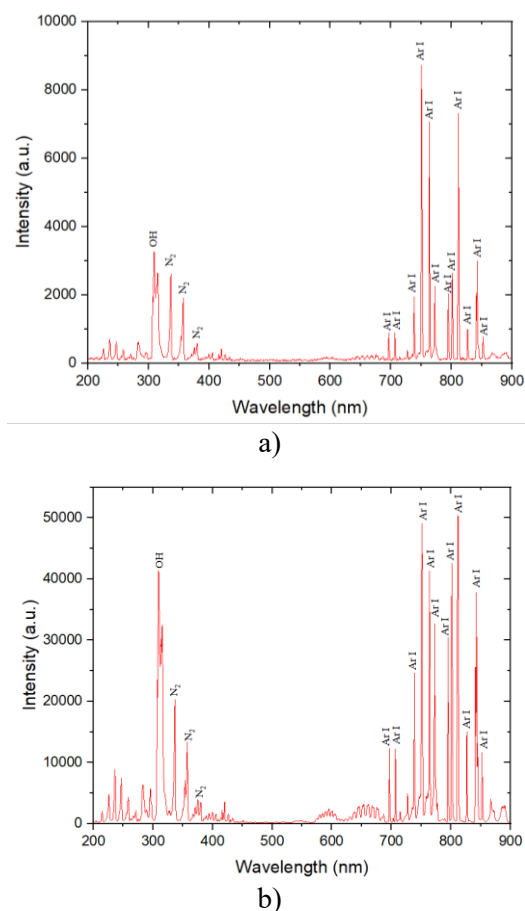

**Figure 3** – Emission spectra of argon plasma at a pressure of 0,5 Torr and at powers of 5 W (a) and 10 W (b).

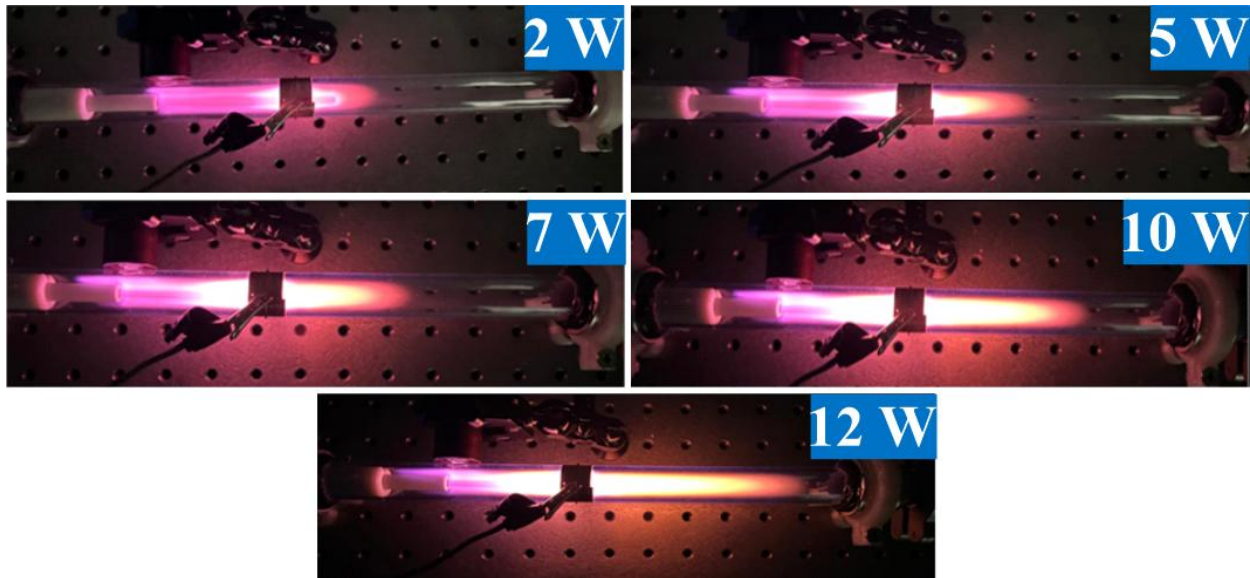

**Figure 4** – Photo of RF-DBD discharge of argon plasma at various powers (2–12 W) with an argon flow rate of 100 sccm and a pressure of 1,0 Torr.

Compared to the experiment at a pressure of 0,5 Torr, there is a noticeable decrease in the overall intensity of the argon spectral lines.

This indicates a decrease in the degree of excitation and ionisation of argon atoms at elevated pressure, despite the same power input.

Based on these results, the following conclusion can be drawn: an increase in the power of the radio-frequency discharge during the generation of argon plasma leads to an increase in electron density and, as a result, to an intensification of the processes of excitation and ionisation of atoms. This is reflected in the increase in the intensity of the spectral emission lines of argon in the range of 695–850 nm. In addition, the spectra show lines corresponding to hydroxyl radicals (OH) with a wavelength of around 310 nm, as well as molecular nitrogen radiation in the 313–400 nm range [12], which indicates the interaction of plasma with residual air gases. Thus, the results of spectral analysis confirm that the power of the RF discharge is a key parameter determining the energy characteristics and composition of argon plasma.

#### Plasma of argon–methane mixture

The Ar–CH<sub>4</sub> gas mixture plasma was obtained by introducing a chemically active gas, methane, into the argon flow. The ratio of components was 95% Ar (95 sccm) and 5% CH<sub>4</sub> (5 sccm). Figure 6 shows photo of the RF-DBD discharge at power levels ranging from 2 to 12 W at a constant pressure of 0,5 Torr. The emission spectra of the Ar–CH<sub>4</sub> plasma at

power levels of 5 W (a) and 10 W (b) are shown in Figure 7.

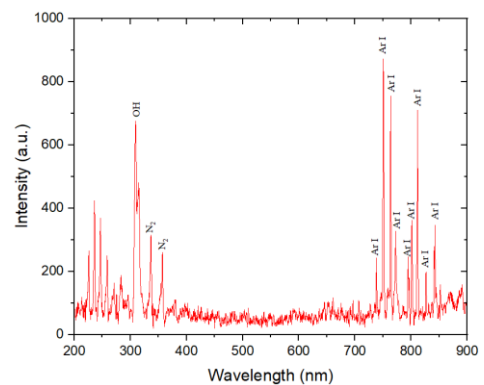

a)

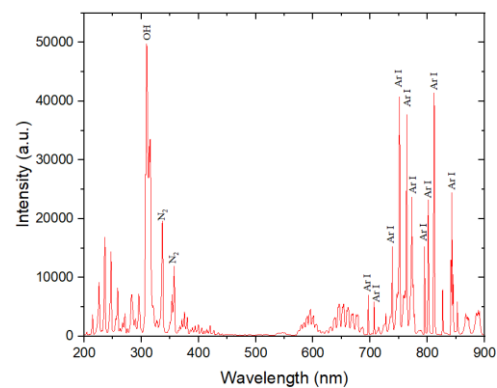

b)

**Figure 5** – Emission spectra of argon plasma at a pressure of 1,0 Torr and at powers of 5 W (a) and 10 W (b).

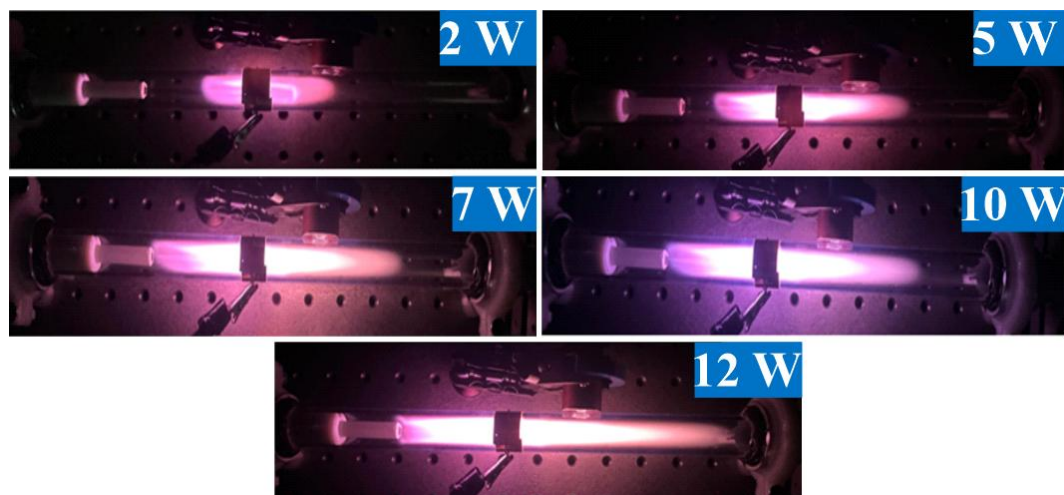

**Figure 6** – Photo of RF-DBD discharge of argon-methane plasma at various powers (from 2 to 12 W) with argon flow rates of 95 sccm and methane flow rates of 5 sccm, at a pressure 0,5 Torr.

With an increase in the power supplied, a gradual expansion of the luminescence area along the quartz tube is observed, indicating an increase in the plasma volume. The addition of methane to the gas mixture leads to an increase in collision energy losses of electrons due to the dissociation and excitation of  $\text{CH}_4$  molecules.

The spectral characteristics show that when the power is increased from 5 to 10 W, the intensity of the argon lines increases, indicating an increase in electron density and ionisation.

Compared to pure argon plasma, the intensity of molecular nitrogen and hydroxyl radical (OH) lines is significantly lower at both 5 W and 10 W. This is due to the fact that a significant part of the electron energy is spent on the excitation and dissociation of methane, rather than on the excitation of impurity molecules in the air.

Images of RF-DBD discharge of argon-methane plasma at powers ranging from 2 W to 12 W and a pressure of 1,0 Torr are presented in Figure 8, and spectral characteristics at powers of 5 W and 10 W are shown in Figure 9. As the supplied power increases, the discharge glow area expands. Compared to the mode at a pressure of 0,5 Torr, the luminescence intensity at 1,0 Torr is significantly lower, which is due to a reduction in the free path length of electrons and an increase in energy losses due to inelastic collisions with gas atoms and molecules at higher pressures.

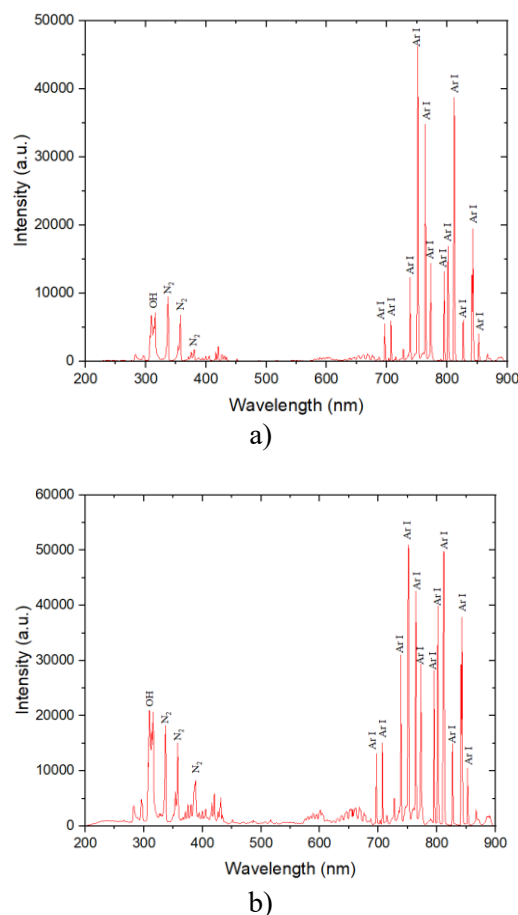

**Figure 7** – Emission spectra of argon-methane plasma ( $\text{Ar}-\text{CH}_4$ ) with argon flow rates of 95 sccm and methane flow rates of 5 sccm, pressure of 0,5 Torr, and power levels of 5 W (a) and 10 W (b).

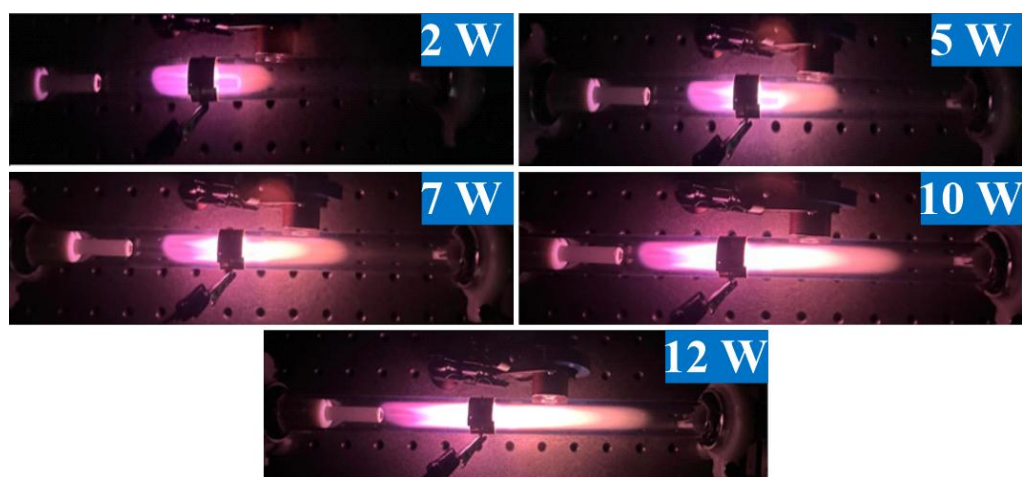

**Figure 8** – Photo of RF-DBD discharge of argon-methane plasma at various powers (from 2 to 12 W) with argon flow rates of 95 sccm and methane flow rates of 5 sccm, at a pressure of 0,5 Torr.

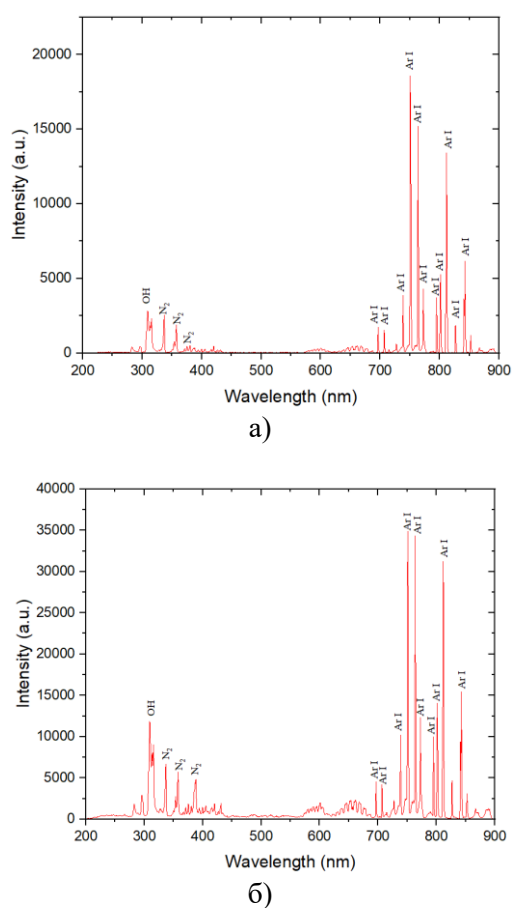

**Figure 9** – Emission spectra of argon-methane plasma (Ar-CH<sub>4</sub>) with argon flow rates of 95 sccm and methane flow rates of 5 sccm, pressure of 1,0 Torr, and power levels of 5 W (a) and 10 W (b).

### Conclusion

This paper investigates the spectral characteristics of argon and argon-methane plasma

obtained in a radio-frequency dielectric barrier discharge (RF-DBD) and determines the optimal discharge parameters.

During the experiments, the pressure varied between 0,5 and 1,0 Torr, and the power supplied ranged from 2 to 12 W. It was established that the minimum threshold power required to maintain the gas discharge plasma is approximately 2 W. With an increase in power, a gradual expansion of the luminescence area and an increase in radiation intensity along the quartz tube are observed. The amplification of atomic argon (Ar I) spectral lines is associated with an increase in electron density, ionisation level, and frequency of electron-impact processes. Spectral data in the 200–900 nm range identified Ar I lines, as well as emission bands of hydroxyl radicals (OH) and molecular nitrogen (N<sub>2</sub>), indicating the partial presence of air in the reactor and evidence of insufficient gas system tightness. When methane is introduced into the gas mixture (Ar:CH<sub>4</sub> = 95:5), a decrease in the intensity of argon lines is observed, which may be associated with the redistribution of electron energy to the processes of excitation and dissociation of methane molecules, as well as with the formation of dust particles in the plasma. The results obtained contribute to a deeper understanding of the physicochemical processes in argon-methane plasma and open up prospects for the further application of RF-DBD discharges in methane plasma conversion tasks.

### Acknowledgments

This research is funded by the Committee of Science of the Ministry of Science and Higher Education of the Republic of Kazakhstan (grant number: AP26198645).

**Author Contributions:**

**Dias Ye. Yelubayev:** Investigation, Visualization, Writing - original draft. **Zhanserik Ye. Ongaibergenov:** Investigation, Visualization, Writing - original draft. **Almasbek U. Utegenov:** Investigation, Formal analysis, Methodology, Visualization, Validation, Writing - original draft, Writing - review & editing. **Rakhymzhan Ye. Zhumadilov:** Investigation, Formal analysis, Methodology, Visualization, Validation, Project administration, Writing - original draft, Writing - review & editing.

**References**

1. S.G. Nnabuife, et al., The prospects of hydrogen in achieving net zero emissions by 2050: a critical review, *Sustainable Chemistry for Climate Action* **2**, 100024 (2023). <https://doi.org/10.1016/j.scca.2023.100024>.
2. J. Hwang, K. Maharjan, H.J. Cho, Review of Hydrogen Utilization in Power Generation and Transportation Sectors: Achievements and Future Challenges, *Int. J., Hydrogen Energy* **48(74)**, 28629–28648 (2023). <https://doi.org/10.1016/j.ijhydene.2023.04.024>.
3. D. Guilbert, G. Vitale, Hydrogen as a Clean and Sustainable Energy Vector for Global Transition from Fossil-Based to Zero-Carbon, *Clean Technol.* **3(4)**, 881–909 (2021). <https://doi.org/10.3390/cleantechnol3040051>.
4. Md M. H. Bhuiyan, Z. Siddique, Hydrogen as an alternative fuel: A comprehensive review of challenges and opportunities in production, storage, and transportation, *International Journal of Hydrogen Energy* **102**, 1026–1044 (2025). <https://doi.org/10.1016/j.ijhydene.2025.01.033>.
5. A. Bogaerts and G. Centi, Plasma Technology for CO<sub>2</sub> Conversion: A Personal Perspective on Prospects and Gaps, *Front. Energy Res.* **8**, 111 (2020). <https://doi.org/10.3389/fenrg.2020.00111>.
6. A. Bogaerts, G. Centi, V. Hessel, and E. Rebrov, Perspectives and Emerging Trends in Plasma Catalysis: Facing the Challenge of Chemical Production Electrification, *ChemCatChem.* **17**, e202401938 (2025). <https://doi.org/10.1002/cctc.202401938>.
7. W.C. Chung, M.B. Chang, Review of Catalysis and Plasma Performance on Dry Reforming of CH<sub>4</sub> and Possible Synergistic Effects Renew, *Sustain. Energy Rev.* **62**, 13–31 (2016). <https://doi.org/10.1016/j.rser.2016.04.007>.
8. W. Ni, O. Hope Otor, G. Rivera-Castro, J. C. Hicks, Plasma Catalysis for Hydrogen Production: A Bright Future for Decarbonization, *ACS Catal.* **14**, 6749–6798 (2024). <https://doi.org/10.1021/acscatal.3c05434>.
9. A. Bogaerts, E.C. Neyts, Plasma Technology: An Emerging Technology for Energy Storage, *ACS Energy Lett.* **3**, 1013–1027 (2018). <https://doi.org/10.1021/acsenerylett.8b00184>.
10. X. Chen, H.-H. Kim, T. Nozaki, Plasma catalytic technology for CH<sub>4</sub> and CO<sub>2</sub> conversion: A review highlighting fluidized-bed plasma reactor, *Plasma Process Polym.* **21**, e2200207 (2024). <https://doi.org/10.1002/ppap.202200207>.
11. R.Snoeckx, A. Bogaerts, Plasma technology – a novel solution for CO<sub>2</sub> conversion? *Chem Soc Rev.* **46**, 5805–5863 (2017). <https://doi.org/10.1039/c6cs00066e>.
12. M. Hoentsch, R. Bussiahn, H. Rebl, C. Bergemann, M. Eggert, et al., Persistent Effectivity of Gas Plasma-Treated, Long Time-Stored Liquid on Epithelial Cell Adhesion Capacity and Membrane Morphology, *PLoS ONE* **9(8)**, e104559 (2014). <https://doi.org/10.1371/journal.pone.0104559>.
13. A. Tazhen, M. Dosbolayev, & T. Ramazanov, Pulsed plasma flow diagnostics, *Recent Contributions to Physics* **81(2)**, 35–39 (2022). <https://doi.org/10.26577/RCPH.2022.v81.i2.05>.
14. A.U. Utegenov, Z.E. Onaibergenov, A.E. Abdrakhmanov, S.A. Orzabayev, & T.S. Ramazanov, Investigation of the temperature of electrons in a glow discharge plasma at direct current Ar and Ar/ C<sub>2</sub>H<sub>2</sub>, *Recent Contributions to Physics* **90(3)**, 2-37 (2024). (In Russ.) <https://doi.org/10.26577/RCPH.2024v90i3-04>.
15. W.I.Yaseen, A.K.Abd, Construction of Multi-Channel Radio Frequency Plasma Jet System in Atmospheric Pressure and the Diagnosis of Plasma Parameters and I-V Characteristics, *Iraqi Journal of Science* **65(9)**, 5026-5036 (2024). <https://doi.org/10.24996/ij.s.2024.65.9.19>.

**История статьи:** поступила: 29 декабря 2025; принята: 20 января 2026.

**Мақала тарихы:** түсті: 29 желтоқсан 2025; қабылданды: 20 қантар 2026.

**Article history:** received: 29 December 2025; accepted: 26 January 2026.

**Information about authors:**

1. **D.Ye. Yelubayev** – PhD student, Institute of Applied Sciences and Information Technologies, Al-Farabi Kazakh National University, Almaty, Kazakhstan. e-mail: [yelubayev.dias@gmail.com](mailto:yelubayev.dias@gmail.com)

2. **Z.E. Ongaibergenov** – undergraduate student, Institute of Applied Sciences and Information Technologies, Al-Farabi Kazakh National University, Almaty, Kazakhstan. e-mail: [onaibergenovz@gmail.com](mailto:onaibergenovz@gmail.com)

3. **A.U. Utegenov** – PhD, Institute of Applied Sciences and Information Technologies, Al-Farabi Kazakh National University, Almaty, Kazakhstan. e-mail: [almasbek@physics.kz](mailto:almasbek@physics.kz)

4. **R.Ye. Zhumadilov** (corresponding author) – PhD, Institute of Applied Sciences and Information Technologies, Al-Farabi Kazakh National University, Almaty, Kazakhstan. e-mail: [rakimzhan@gmail.com](mailto:rakimzhan@gmail.com)

**Авторлар туралы мәлімет:**

1. **Д.Е. Елубаев** – PhD докторанты, Әл-Фараби атындағы Қазақ ұлттық университеті, Алматы, Қазақстан, e-mail: [yelubayev.dias@gmail.com](mailto:yelubayev.dias@gmail.com)

2. **Ж.Е. Оңайбергенов** – Әл-Фараби атындағы Қазақ ұлттық университеті, Алматы, Қазақстан, e-mail: [onajbergenovz@gmail.com](mailto:onajbergenovz@gmail.com)

3. **А.У. Өтегенов** – PhD докторы, Әл-Фараби атындағы Қазақ ұлттық университеті, Алматы, Қазақстан. e-mail: [almasbek@physics.kz](mailto:almasbek@physics.kz)

4. **Р.Е. Жұмаділов** (автор-корреспондент) – PhD докторы, Әл-Фараби атындағы Қазақ ұлттық университеті, Алматы, Қазақстан. e-mail: [rakimzhan@gmail.com](mailto:rakimzhan@gmail.com)

**Сведения об авторах:**

1. **Д.Е. Елубаев** – PhD студент, Институт прикладных наук и информационных технологий, Казахский национальный университет им. Аль-Фараби, Алматы, Казахстан, e-mail: [yelubayev.dias@gmail.com](mailto:yelubayev.dias@gmail.com)

2. **Ж.Е. Оңайбергенов** – студент бакалавриата, Институт прикладных наук и информационных технологий, Казахский национальный университет им. Аль-Фараби, Алматы, Казахстан, e-mail: [onajbergenovz@gmail.com](mailto:onajbergenovz@gmail.com)

3. **А.У. Утегенов** – PhD, Институт прикладных наук и информационных технологий, Казахский национальный университет им. Аль-Фараби, Алматы, Казахстан. e-mail: [almasbek@physics.kz](mailto:almasbek@physics.kz)

4. **Р.Е. Жумадиллов** (автор-корреспондент) – PhD, Институт прикладных наук и информационных технологий, Казахский национальный университет им. Аль-Фараби, Алматы, Казахстан. e-mail: [rakimzhan@gmail.com](mailto:rakimzhan@gmail.com)